



Elektrinis kanalinis šildytuvas

Electric duct heater

Elektro-Heizregister für Lüftungssysteme

Электрические каналные нагреватели



Elektriniai kanaliniai šildytuvai skirti švaraus oro pašildymui ventiliacijos sistemose.

Korpusai pagaminti iš skardos, padengtos AlZn, kurios paviršius atsparus aukštai temperatūrai. Kaitinimo elementų vamzdelis pagamintas iš nerūdijančio plieno AISI 304.

Šildytuvuose yra sumontuotos dvi termoapsaugos, elektrinio pajungimo gnybtai. Korpusas yra su sandarinimo gumomis, pajungimui prie ortakio.

Šildytuvai gali būti montuojami horizontaliai ir vertikalčiai.

Maksimali pašildyto oro temperatūra 50°C.



Sie finden bei den Lüftungssystemen Verwendung. Das runde Gehäuse der Kanal-Erwärmungseinrichtung ist aus mit Aluzink beschichtetem Stahlblech hergestellt, und das Spiralheizelement - aus rostfreiem Stahl AISI 304. Die Erwärmungseinrichtungen mit einer Leistung von 0,3 kW bis 2,4 kW können in jeder beliebigen Stellung montiert werden. Die 3-12 kW-Erwärmungseinrichtungen dürfen nicht so montiert werden, dass der Stromanschlusskasten nach unten gerichtet ist. Die Luftstromgeschwindigkeit durch die Erwärmungseinrichtung darf nicht geringer als 1,5 m/s sein. Die Maximaltemperatur der erwärmten Luft 50°C.



Electric heaters are designed to heat clean air in ventilation systems.

Casing is made from aluzinc coated steel which is high temperature proof. Heating elements tube is made from stainless steel AISI 304.

In heaters are installed 2 protection thermostats, screw terminals for easy connection. Casing is with rubber seals for duct connection.

Heaters can be installed vertically or horizontally.

Maximum output air temperature 50°C.



Электрические каналные нагреватели предназначены для подогрева чистого воздуха в вентиляционных системах.

Корпус изготовлен из алюмоцинкованной стали, поверхность которой устойчива к высоким температурам. Трубка тена изготовлена из нержавеющей стали AISI 304. В нагревателе установлены 2 термозащиты, клеммы электрического подключения, корпус с уплотнительными резиновыми кольцами для подключения к воздуховоду.

Нагреватели могут быть установлены горизонтально и вертикально.

Максимальная температура подогреваемого воздуха 50°C.

Accessories



TJK
p. 150



EKR 15
p. 140



EKR 6
p. 142

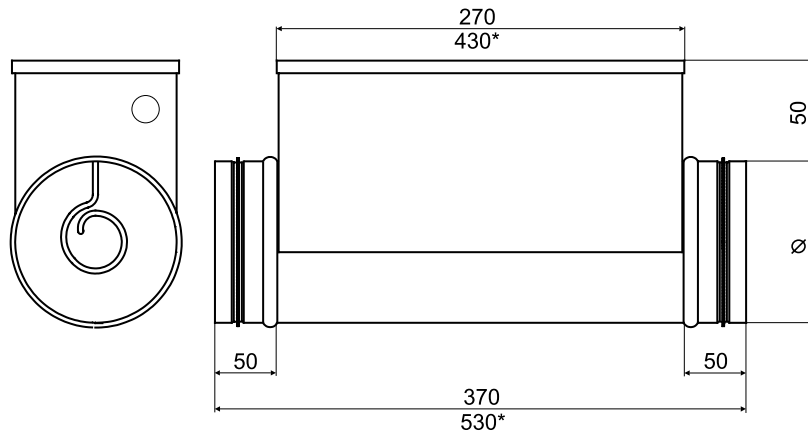

All dimensions in mm
* Dimensions of 12 kW heaters

Technical data

Type	Diameter mm]	Min. airflow [m ³ /h]	Voltage V/50Hz]	Power [kW]	Nominal current, I _n [A]
EKA 100	100	40	1~ 230	0,3/0,6/0,9/1,2	1,4/2,8/4,1/5,5
EKA 125	125	70	1~ 230	0,3/0,6/0,9/1,2/1,5/1,8	1,4/2,8/4,1/5,5/6,8/8,2
EKA 160	160	110	1~ 230	1,2/2,0/2,4	5,5/9,1/10,9
			2~ 400	3,0/5,0/6,0	7,9/13,2/15,8
			3~ 400	6,0	8,7
EKA 200	200	170	1~ 230	1,2/2,0/2,4	5,5/9,1/10,9
			2~ 400	3,0/5,0/6,0	7,9/13,2/15,8
			3~ 400	6,0	8,7
EKA 250	250	270	1~ 230	1,2/2,0/2,4	5,5/9,1/10,9
			2~ 400	3,0/5,0/6,0	7,9/13,2/15,8
			3~ 400	6,0/9,0	8,7/13,0
EKA 315	315	415	1~ 230	1,2/2,0/2,4	5,5/9,1/10,9
			2~ 400	3,0/5,0/6,0	7,9/13,2/15,8
			3~400	6,0/9,0/12,0	8,7/13,0/17,3
EKA 400	400	690	2~ 400	3,0/5,0/6,0	7,9/13,2/15,8
			3~ 400	6,0/9,0/12,0	8,7/13,0/17,3

Electrical heaters conforms to requirements of standards IEC 60335-2-30 : 1996, LST EN 600335-2-30 : 1999, LST EN 61010-1+A2 : 2000, LST EN 50081-2 : 1995, LST EN 55011 : 1999+A1 : 2001 and carries CE mark.

Overheat protection

All EKA duct heaters has two-stage overheat protection: the first stage switches on when the temperature reaches 50°C (resets automatically), the second stage switches on when the temperature reaches 100°C (is reset manually with pushbutton on the casing).

EKA has no internal temperature controller. External heating controllers EKR are used in this case. Heaters with internal temperature controller (EKA...NV, EKA...NI and EKA...NIS) have this controller.

EKA ...NV

Heaters with integrated temperature controller, temperature setpoint internal

Heaters EKA ...NV with integrated temperature control contains temperature regulator which works by algorithm impulse/pause, that enables fine temperature control. Regulator controls load by triacs without moving parts, which causes no-noise commutation. Potentiometer is used to set

temperature. Manual thermocontact restoration button and temperature setpoint are located on the case of a heater.

The room temperature sensor or duct temperature sensor is needed.

EKA ...NI

Heaters with integrated temperature controller, temperature setpoint external

Heaters EKA ...NI with integrated temperature control, contains temperature regulator which works by algorithm impulse/pause, that enables fine temperature control. Regulator controls load by triacs without moving parts, which causes no-noise commutation. External temperature setpoint must

be connected separately. The button of manual restoration located on the case of a heater.

The room temperature sensor or duct temperature sensor and potentiometer is needed.

EKA ...NIS

Heaters with integrated temperature controller, external control signal

Heaters EKA ...NIS with integrated temperature control, contains temperature regulator which works by algorithm impulse/pause, that enables fine temperature control. Regulator controls load by triacs without moving parts, which causes no-noise commutation. The button of manual restoration

located on the case of a heater.

The external control signal (0-10V) is needed. 0V voltage adequate to temperature 0°C, and 10V voltage adequate to temperature 30°C.

Temperature regulator EKR-K...

Temperature controller EKR-K... is installed into electrical heaters EKA -NV, -NI, -NIS

Voltage:	1 phase - 230V
	2 phase - 400V
	3 phase - 400V
Ambient temperature:	0 - 40° C
Humidity:	max 80%
Adjustment range of temperature:	0 - 30° C.
Temperature is adjusted by:	internal or external potentiometer.
Input signal for temperature control:	0...10V DC.

The PCB is equipped with internal fuses F1 and F2 on 50 mA. Their applicability, to protect PCB from the increased current.